

# SB10000

**Technology Description**- Floating, solar powered, circulation equipment for wastewater treatment and freshwater applications. Day/night operation on solar only by utilizing a battery to store excess daytime power for nighttime operation.

**Materials of Construction** - T316 stainless steel construction. Foam-filled high-density polyethylene (HDPE) floats. Thermoplastic rubber intake hose. HDPE strainer. Concrete mooring blocks are encapsulated in HDPE.

**Machine Size / Weight** - Assembled machine is 16 feet (5 m) in diameter and weighs 850 pounds (380 kg).

**Drive System** - High torque, direct drive (no gearbox), low voltage brushless D.C. motor.

**Minimum Operating Depth** - 31 inches (0.8 m) with fixed horizontal plate. No damage to machine or bottom of reservoir when run dry in shallow water.

**Flotation System** - Three floats in triangular pattern each with an adjustable float arm for proper vertical positioning, total float buoyancy of 1,450 lbs (660 kg).

**Rotating Assembly** - Removable assembly with easy access to motor and digital controller. Impeller handles 4-inch (10 cm) spherical solids. Oil-filled (food grade) teflon freeze sleeve with o-rings, shaft. Rotational indicator on shaft.

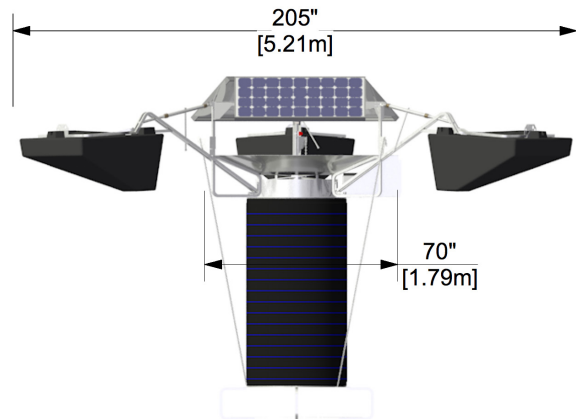

Figure 1: SB10000

**Power Supply/Control System** - Photovoltaic (PV) Solar Panels are protected from bird fouling with bird deterrent kit.

**PV Solar Panels:** 3 X 80-watt photovoltaic solar panels. Onboard battery storage for day/night operation.

**Electronic Controller:** Digital solid-state controller, mounted in weather-tight (NEMA 4X) enclosure with externally fused disconnect. SCADA output through RS-232 serial communication (Modbus RTU), DB9 male connection point inside enclosure. Wireless options available, not included.

**Wiring:** Corrosion-resistant industrial cord with molded watertight connectors that are indexed to prevent improper wiring.

**Flow Rates** - Flow Rates at full speed at 10 feet (3.0 m) diameter.

**Direct Flow Rate:** 3,000 gallons per minute (12,000 liters per minute).

**Induced Flow Rate:** 7,000 gallons per minute (26,000 liters per minute).

**Combined Flow Rate:** 10,000 gallons per minute (38,000 liters per minute).

**Fluid Intake Assembly - Option 1** - Intake hose assembly bolted to bottom of structural assembly.

**Hose System:** 10 to 100 feet (3 to 30.5 meters) available in 36 inch (91 cm) diameter X 10, 15, or 20 feet (3, 4.5 or 6 meter) sections.

**Intake Type:** Fixed horizontal plate with 12-inch (31 cm) openings.

**Intake Depth Adjustment:** 15 feet (4.5 m) of field adjustment with three SS chains connected to hose coupling.

**Fluid Intake Assembly - Option 2** - Fixed horizontal plate bolted to bottom of structural assembly.

**Intake Type:** Fixed horizontal plate with 12-inch (31 cm) openings.

**Intake Depth Adjustment:** No adjustment necessary. Horizontal inflow from 25-inch (64 cm) below distribution dish.

**Fluid Intake Assembly - Option 3** - See SB10000DM Dual Mix Features Sheet.

**Anchoring** - (1) Two mooring blocks tethered together with SS chain and attached to structural member on unit or  
(2) Tethered to shore with SS cable.

**Ice Protection** - Freeze sleeve and positive pumping under distribution dish to maintain circulation.

**Accessories Available** - (1) Supplemental Shore Power Kit, (2) Chemical Injection Kit, (3) Marker Light Kit

**Shipping Size / Weight** -

- **Crate** - 87 inch W X 87 inch L X 65 inch H (2.2 m x 2.2 m x 1.7 m) / 1,500 pounds (680 kg)

*Exact weight and dimensions varies dependent on machine configuration.*

**Life / Maintenance / Warranty** - Expect 25-year life, minimal maintenance. Limited 2-year parts and labor warranty. Limited 25-year photovoltaic module manufacturer performance warranty and 10-year motor warranty.