



GS-12-Air

Technology Description- GridBee® electric submersible water circulation equipment, designed for continuous operation. Constructed with T316 stainless steel shell and safe materials for contact with potable drinking water. Designed to be placed into service through roof hatch without tank entry.

Materials of Construction - T316 stainless steel shell and hardware construction. GridBee® submersible mixers are constructed using safe materials for contact with potable water. See certifications section below.

100 ft (30 m) of T316 stainless steel retrieval chain included for machine installation and retrieval without requiring tank entry.

Minimum Access Opening - Machine can be placed through 12 inch (30 cm) diameter opening.

Minimum Water Depth - Machine requires 20 in (0.5 m) of water to effectively circulate. No damage to machine when run dry in shallow water or drained condition.

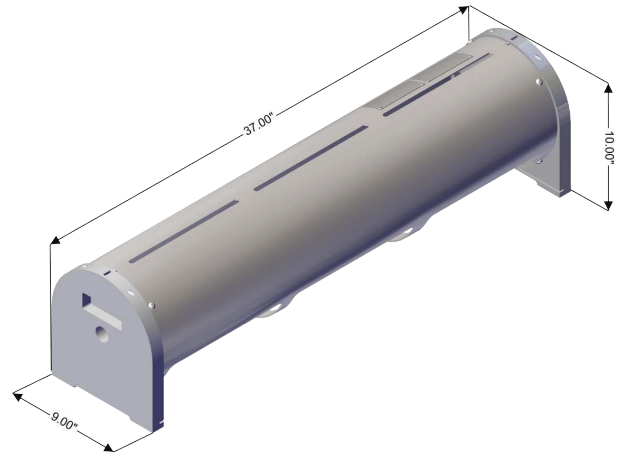

Figure 1: GS-12-Air

Maximum Operating Depth - Maximum air discharge depth is limited by the air supply pressure available.

Electrical Requirements - 120VAC motor requires 120VAC/1PH power source outlet (**minimum 20 Amp service**).

Recommended Air Supply - Machine is provided with a 1/2 inch air hose connection point.

1 HP Compressor Unit - AC655 - 1 HP (655 Watt) rated compressor capable of producing 4.3 standard cubic feet per minute (0.13 standard cubic meters per minute) @ 15 psi (105 kiloPascal). Mounted to steel skid, includes brass fittings, air inlet filter, 0-60psi pressure gauge, and pressure relief. Maximum Pressure of 40 psi (275 kiloPascal). Continuous duty-cycle. Requires 120vAC, 20 Amp Service. Current range: 2.5 amps (open discharge) - 5.3 (dead head). Connection: 3/8" FNPT with 3/4" hose barb. Size: 18" L x 10.5" W x 15.5" H. High Pressure unit for specific application requirements is available upon request. For self-supplied air source, please contact Medora Corporation.

Optional Accessories - Additional standard hose available in 100' length.

Machine Size / Weight

- 37 in (93.98 cm) long x 10 in (25.4 cm) height x 9 in (22.9 cm) width / 50 lbs (23 kg)

Enclosed Area Warning - Air powered mixers should not be used in enclosed areas where methane or other explosive gases could build up. Some gases can explode when combined with air. Please verify that you have proper ventilation to prevent a buildup of methane gas or other gases in the headspace above the explosion limit.

Certifications - Medora Corporation's potable water products are certified to ANSI/NSF Standard 61, and 372 for lead-free content. Learn more at: www.medoraco.com/std61

Life / Maintenance / Warranty - 25-year design life, limited maintenance. Limited 5-year parts and labor warranty. See Warranty Statement for details.

