

AP1800

Technology Description- GridBee® air powered circulation equipment are made of lightweight and long lasting plastic. Anchored from the bottom and self floating, the AP1800 stays out of sight but allows for mixing of small ponds and lake with no part of the machine above the water. Specifically designed for small ponds and docks.

Materials of Construction - High density polyethylene shell and T316 stainless steel hardware. Syntactic foam flotation with rubberized coating. EPDM weighted air hose, and polypropylene air hose fittings.

10 ft (3 m) T316 stainless steel retrieval chain included for machine anchoring.

Minimum Water Depth - Machine requires 36 inches (1M) of water to effectively circulate. No damage to machine when run dry in shallow water or drained condition.

Water Depth - For air manifold depth settings of less than 12ft (3.6 m), air pump configurations are recommended. For application at greater than 12ft (3.6 m), compressor configurations are recommended.

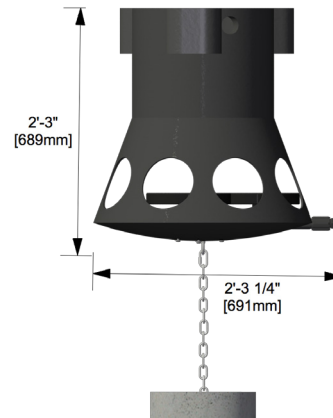

Figure 1: AP1800

Intake - The chain from anchor to the bottom of the AP1800 determines the intake level. The Intake draws water in a horizontal layer from the set distance off of the reservoir floor.

Timer - Input voltage: 120 VAC, 60 HZ, 15 Amps General Purpose, 1000 Watts Tungsten, 1/4 Horsepower, 8.3 Amps Ballast (Standard) (Inductive), 500 VA Electronic Ballast. Programmable digital timer for outdoor applications.

Shipping Size/Weight

- 48" x 40" x 36", 160lbs.

Life / Maintenance / Warranty- 25 year expected life, limited maintenance. Limited manufacture's warranty. See Warranty Statement for details.