

SB5000PW

Technology Description- Floating, solar powered, circulation equipment for potable water reservoirs. Day/night operation on solar only by utilizing a battery to store excess daytime power for nighttime operation.

Materials of Construction - NSF/ANSI Standard 61- T316 stainless steel construction. Foam-filled high-density polyethylene (HDPE) floats. Thermoplastic rubber intake hose. HDPE strainer. **The SB5000PW is NSF / ANSI Standard 61 Certified, includes NSF/ANSI 61, Annex G.**



Minimum Access Opening / Machine Size / Weight -

Machine can be assembled through 3 feet by 3 feet (92 cm by 92 cm) clear opening. Assembled machine is 16 feet (5 m) in diameter and weighs 850 pounds (380 kg).

Drive System - High torque, direct drive (no gearbox), low voltage brushless D.C. motor.

Minimum Operating Depth - At depths below 5 feet (1.5 m), the impeller will be out of the water and the machine will stop circulating water. No damage to machine when run dry in shallow water. 26 inch (0.6 meter) headspace is required.

Flotation System - Three floats in triangular pattern each with an adjustable float arm for proper vertical positioning, total float buoyancy of 1,400 lbs (660 kg).

Rotating Assembly - Removable assembly with easy access to impeller and impeller shaft.

Power Supply/Control System - Photovoltaic (PV) Solar Panels , Battery and Electronic Controller are mounted on rack outside.

PV Solar Panels: 3 X 80-watt photovoltaic solar panels. Battery storage for day/night operation.

Electronic Controller: Digital solid-state controller, mounted in weather-tight (NEMA 4X) enclosure with internally fused disconnect. SCADA output through RS-232 serial communication (Modbus RTU), DB9 male connection point inside enclosure. Wireless options available, not included.

Wiring: Corrosion-resistant industrial cord with molded watertight connectors that are indexed to prevent improper wiring.

Fluid Intake Assembly - Intake hose bolted to bottom of structural assembly.

Intake Hose : 20 to 60 feet (6 to 18 m) available in 16-inch (40 cm) diameter X 20 feet (6 m) sections.

Intake Assembly at Bottom of Hose: Rectangular intake with openings around perimeter.

Intake Depth Adjustment: No depth adjustment is necessary for fluctuations in water level. Intake draws water in a horizontal layer within 1 inch (2.5 cm) of the tank or reservoir floor.

Chlorine Boosting - Chlorine boost hose, accessible at top of reservoir spans down and connects to intake for fast chlorine dispersion during in-reservoir boosting.

Accessories Available - (1) Portable Chlorine Boost System, (2) LED RPM Indicator, (3) Supplemental Power Kit, and (4) Wireless SCADA Kit.

Shipping Size / Weight -

- **Crate -** 87 inch W X 87 inch L X 65 inch H (2.2 m x 2.2 m x 1.7 m) / 1,500 pounds (680 kg)
Exact weight and dimensions varies dependent on machine configuration.

Life / Maintenance / Warranty - Expect 25-year life, minimal maintenance. Limited 2-year parts and labor warranty. Limited 25-year photovoltaic module manufacturer performance warranty and 10-year motor warranty.

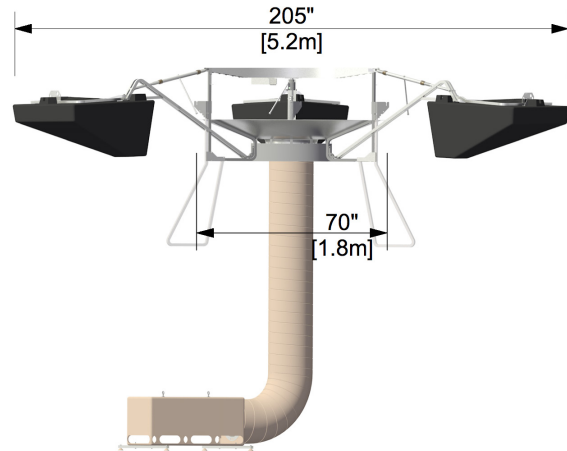

Figure 1: SB5000PW