

GF2500

Technology Description- Floating, AC powered, circulation equipment for wastewater treatment and freshwater applications. Continuous operation on single-phase AC power.

Materials of Construction - T316 stainless steel constructions. Foam-filled high-density polyethylene (HDPE) floats. Thermoplastic rubber intake hose. HDPE Strainer.

Flow Rates -

Flow rates at full speed at 10 feet (3.0 meter) diameter

Direct Flow Rate: 350 gpm (1,320 lpm)

Induced Flow Rate: 2,150 gpm (8,150 lpm)

Combined flow Rate: 2,500 gpm (9,470 lpm)

Drive System - High torque, direct drive (no gearbox), low voltage brushless D.C. motor.

Minimum Water Depth - Minimum of 30 inches (0.8m) operating depth required with fixed horizontal plate. No damage to machine or bottom of reservoir when run dry in shallow water.

Flotation System - Three floats in triangular pattern each with an adjustable float arm for proper vertical positioning, total float buoyancy of 1,450 lbs (660kg).

Electrical Requirements - *Requires single phase 120VAC / 60Hz / 15 Amp Service. (Not supplied by Medora Corp.)*

Wiring Controls - Includes power box which converts 120VAC to low voltage DC power. Includes submersible, SOOW type, cable with inhibitors for UV protection. SCADA accessory compatible.

Rotating Assembly - Removable assembly with easy access to motor and power box. Impeller handles 4-inch (10cm) spherical solids. Oil-filled (food grade) teflon freeze sleeve with o-rings, shaft. Rotational indicator on shaft.

Fluid Intake Assembly - Option 1 - *Hose system bolted to bottom of structural assembly.*

Hose System: 20 to 60 feet (6 to 18m) available in 12-inch (30cm) diameter x 20 feet (6m) sections.

Intake Type : Inverted bell shape strainer with 3-inch (7.6cm) holes.

Intake Depth Adjustment: Can vary from 0 to 60 feet (0-18m). No depth adjustment necessary for fluctuations in water level. Weight and flotation of the 'J' bend of hose keeps intake above sludge or bottom of pond at all operating depths. Strainer can be chained up higher if desired.

Fluid Intake Assembly - Option 2 - Fixed horizontal plate bolted to bottom of structural assembly.

Intake Type : Fixed horizontal plate with 12-inch (30cm) openings.

Intake Depth Adjustment: No adjustment necessary. Horizontal inflow from 25 in (64cm) below distribution dish.

Anchoring - Tethered to shore with SS cable.

Ice Protection - Freeze sleeve and positive pumping under distribution dish to maintain circulation.

Accessories Available - (1) Chemical Injection Kit (2) SCADA Accessories

Shipping Size / Weight

- **Crate** - 87in x 87in x 65in (2.2m x 2.2m x 1.7m) / 1500lbs (680kg) *Exact weight and dimensions varies dependent on machine configuration.*

Life / Maintenance / Warranty - 25-year design life, minimal maintenance. Limited 2-year parts and labor warranty. 10 year motor warranty.

Patent Pending

Subject to change without notice.

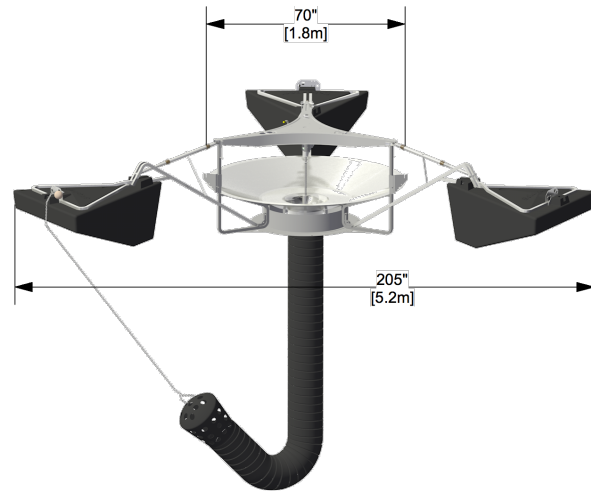

Figure 1: GF2500