



AP7000 & AP8000

Technology Description- GridBee® air powered circulation equipment are made of corrosion resistant, 316 stainless steel with a durable clog-free design and no moving parts for low maintenance. The AP7000 and AP8000 can be used in various applications.

Materials of Construction - T316 stainless steel frame and hardware. EPDM and PVC air hose and polypropylene air hose fittings. (See Figure 1)

10 ft (15.24 m) T316 stainless steel retrieval chain included for machine retrieval.

Recommended Air Flow - 8 to 64 standard cubic feet per minute (0.23 to 1.8 standard cubic meters per minute) @ 1psi (7.0 kiloPascal) + head pressure of water height above intake plate level. 1.5" MNPT air connection point.

Minimum Water Depth - Machine requires 48 inches (1.22M) of water to effectively circulate. No damage to machine when run dry in shallow water or drained condition.

Maximum Water Depth - Maximum air discharge depth is limited by the air supply pressure available.

Floating Accessory - Floating option available, float balls and short chain included to allow for adjustable intake depth with respect to water surface.

Comparison - AP7000 intake plate is solid, while the AP8000 has an 18" hole in the center of the intake plate for drawing water from below the intake level. (See Figure 2)

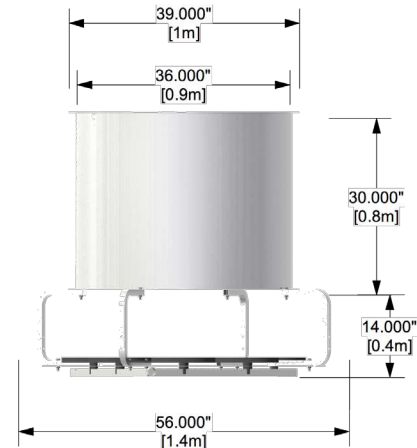

Figure 1: AP7000 & AP8000

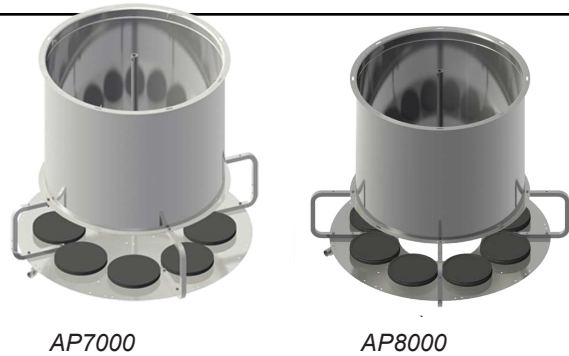

Figure 2

Intake - The submergence depth on a pedestal unit is simply set by either the floor it rests on or for a suspended unit by the vertical suspending cable or chain.

Enclosed Area Warning - Air powered mixers should not be used in enclosed areas where methane or other explosive gases could build up. Some gases can explode when combined with air. Please verify that you have proper ventilation to prevent a buildup of methane gas or other gases in the headspace above the explosion limit.

Shipping Size/Weight

- **AP7000 / AP8000** - 52" x 52" x 48", 300lbs.
- **100 ft Air Hose** - 1.5 inch (38mm) - 51lbs.

Life / Maintenance / Warranty- 25 year expected life, limited maintenance. Limited manufacture's warranty. See Warranty Statement for details.