

AP4000

Technology Description- GridBee® air powered circulation equipment are made of corrosion resistant, 316 stainless steel with a durable clog-free design and no moving parts for low maintenance. The AP4000 stays out of sight but allows for mixing of small ponds and lake with no part of the machine above the water. Specifically designed for small ponds and docks.

Materials of Construction - T316 stainless steel frame and hardware. EPDM and PVC air hose and polypropylene air hose fittings. (See Figure 1)

10 ft (15.24 m) T316 stainless steel retrieval chain included for machine retrieval.

Recommended Air Flow - 6 to 30 standard cubic feet per minute (0.17 to 0.85 standard cubic meters per minute) @ 1psi (7.0 kiloPascal) + head pressure of water height above intake plate level. 1" MNPT Air connection point.

Minimum Water Depth - Machine requires 36 inches (0.92M) of water to effectively circulate. No damage to machine when run dry in shallow water or drained condition.

Maximum Water Depth - Maximum air discharge depth is limited by the air supply pressure available.

Intake - The submergence depth on a pedestal unit is simply set by either the floor it rests on or for a suspended unit by the vertical suspending cable or chain.

Floatation Accessory - Floating option available, float balls and short chain included to allow for adjustable intake depth with respect to water surface.

(Optional Accessory) AU-200- 1/2 HP (375 watt) rated air pump unit capable of producing 6.0 standard cubic feet per minute (0.17 standard cubic meters per minute) @ 4.0 psi (27.6 kiloPascal). 100% duty-cycle. Connection: Stem for 3/4" I.D. hose. Powered by an air pump with a maximum diffuser submergence depth of 12ft (3.7M) . Weather resistant construction, suitable for outdoor use. Ensure unit receives proper shade and ventilation to reduce chance of overheating. (See Figure 2)

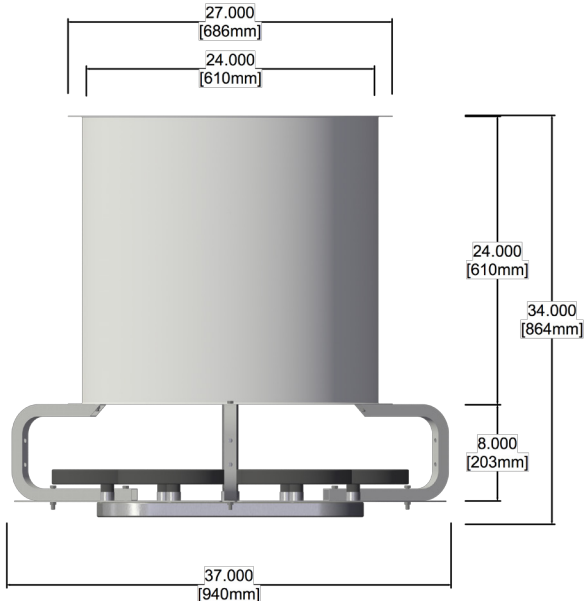

Figure 1: AP4000

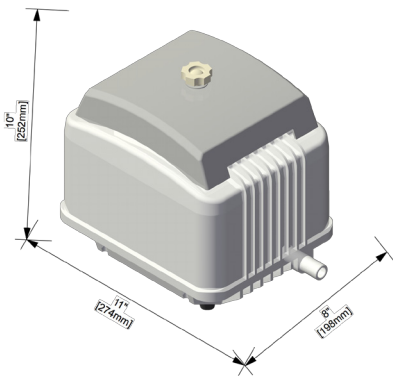

Figure 2: AU-200

Shipping Size/Weight

- **AP4000** - 42" x 42" x 48", 150lbs.
- **AU-200** - 20" x 12" x 16", 30lbs. (Optional)
- **100 ft Air Hose** - 36lbs. (Optional)

Electrical Requirements - Optional AU-200 Air pump requires 120VAC/1PH power source outlet (minimum 20 Amp service), Current range: 3.8 amps (open discharge) - 2.2 (dead head).

Life / Maintenance / Warranty- 25 year expected life, limited maintenance. Limited manufacture's warranty. See Warranty Statement for details.

Patent Pending

Subject to change without notice.